

SAMSYS⁺

Innovative. Intelligent. Precise.

Short bar feeder with servo drive SAMSYS Smart



Advantages of the SAMSYS SMART

- » No special requirements or restrictions on material straightness
- » Material rotates within machining area and spindle length of lathe
- » Lathe spindle speed can be maximized
- » Material can be round or hexagonal
- » Material length can be uniform or random
- » Operating and maintaining easily
- » Small footprint
- » Affordable investment costs

- » User friendly key-board. Easy to handle and understand, all functions are controlled with only 12 input buttons
- » Electrical circuit: main board developed by SAMSYS
- » Double guide rod is labor saving, designed for replacing spindle liners quickly and easily



The Smart short bar loader impresses with its performance across the board.

Diameter	5 – 65 mm
Bar length	max. 1200 mm
Loading capacity	630 mm, Ø 10 mm x 62 pcs.
axis retraction	X = 340mm
Loading Cycle	7 - 22 Sek.
Motor	Servo
Air pressure	5 – 7 kg / cm ²
Power supply	220/380 V ; 0,4 A ; 50/50 Hz
Net weight	345 kg

Loading cycle

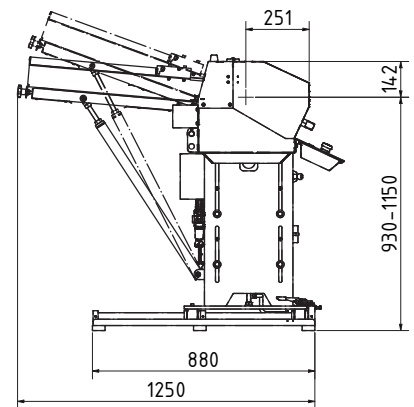
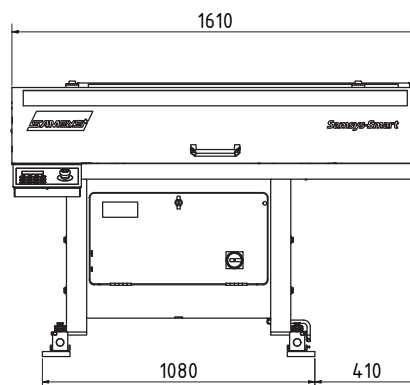
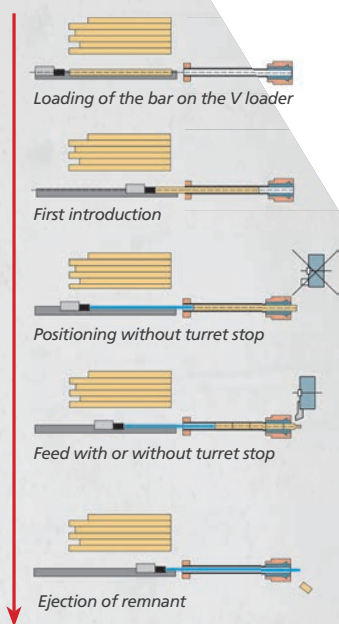

SAMSYS⁺

Innovative. Intelligent. Precise.

SAMSYS GmbH

Obere Schanzenstr. 1-7 | 55232 Alzey / GERMANY

Tel: +49 (0) 6731 / 99 89 95-0 | Fax: +49 (0) 6731 / 54 87 96 4

E-Mail: contact@samsys.eu | www.samsys.eu