



DATASHEET

SG BASE PART AND SG SILICONE TOOLS

V1.1

1 Datasheet

1.1 SG Base Part

| General Properties | Minimum | Typical | Maximum | Unit |
|------------------------------|---------------------------|---------------|------------|--------------------|
| Total spindle stroke | 11 0.43 | - | 40 1.57 | [mm] [inch] |
| Spindle position resolution | - | 0.1 0.0039 | - | [mm] [inch] |
| Spindle force | - | - | 380 | [N] |
| Spindle speed | - | - | 37 1.46 | [mm/s] [inch/s] |
| Gripping time* (SG-a-H) | - | - | 32 | [grip/min] |
| SG-tool attachment mechanism | Smart lock | | | |
| Motor | Integrated, electric BLDC | | | |
| IP Classification | IP67 | | | |
| Dimensions (H x Ø) | 84 x 98 3.3 x 3.85 | | | [mm] [inch] |
| Weight | 0.77 1.69 | | | [kg] [lb] |

*Gripping time is tool depended. See the separate SG Datasheet for the tool specific gripping time.

| Operating Conditions | Minimum | Typical | Maximum | Unit |
|------------------------------------|---------|---------|-----------|--------------|
| Power supply | 20 | 24 | 25 | [V] |
| Current consumption | 45 | - | 600 | [mA] |
| Operating temperature | 0 32 | - - | 50 122 | [°C] [°F] |
| Storage temperature | 0 32 | - - | 60 140 | [C] [F] |
| Relative humidity (non-condensing) | 0 | - | 95 | [%] |
| Calculated MTBF (operating life) | 30.000 | - | - | [Hours] |

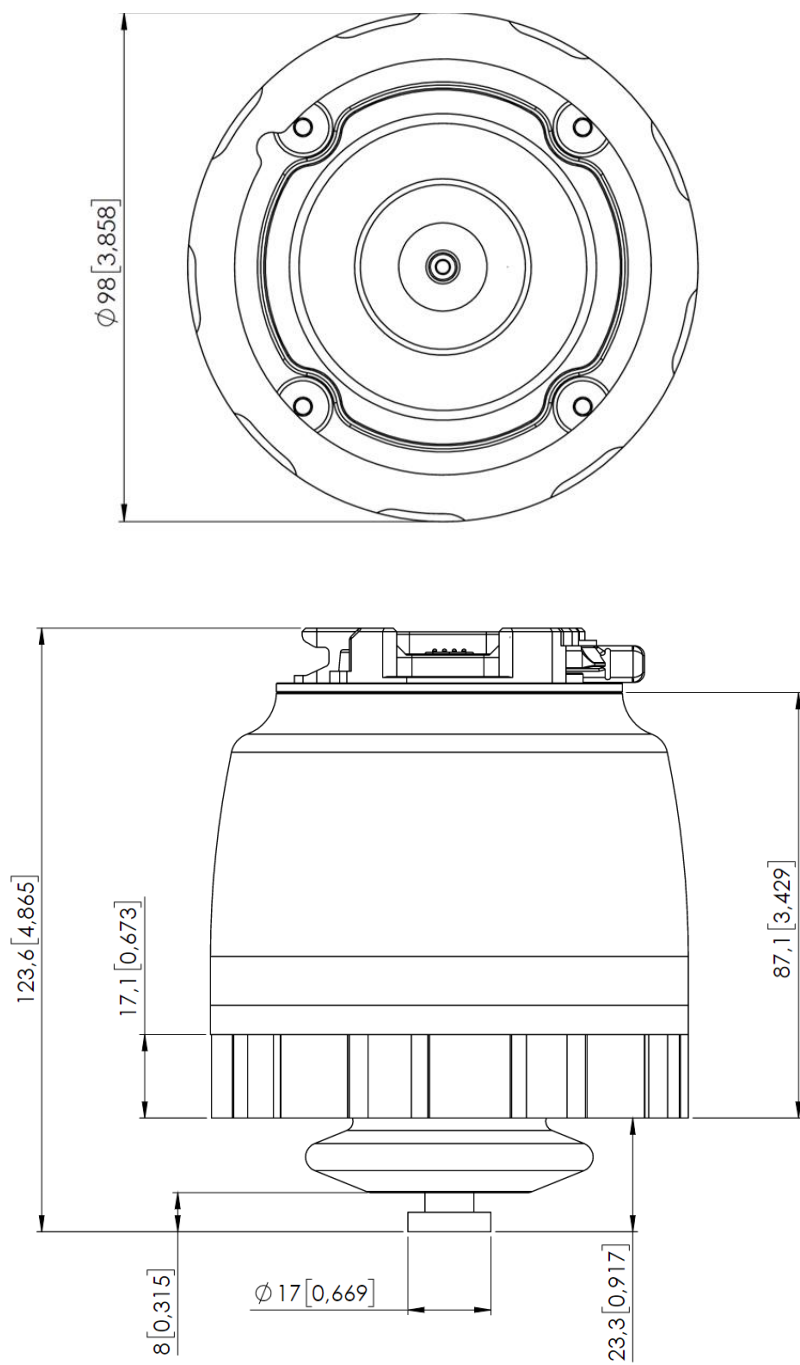

All dimensions are in mm and [inches].

1.2 SG Tools - general

The following SG tools are available:

- SG-a-H
- SG-a-S
- SG-b-H

The letter a and b show the size and shape of the tool and the letter H and S shows whether the tool is Hard (H) or Soft (S)

| General Properties | Minimum | Typical | Maximum | Unit |
|------------------------------|-------------------------------------|---------|-----------|------------|
| Material | Two-component silicone rubber | | | |
| Food approval | FDA 21 CFR 177.2600* & EC 1935/2004 | | | |
| Operation cycles | 2.000.000 | - | - | [cycles] |
| Storage temperature | 0 32 | | 60 140 | [C] [F] |
| Operation temperature | -20 -4 | | 80 176 | [C] [F] |
| SG-tool attachment mechanism | Quick-lock and Smart-lock | | | |
| Washable | Dishwasher safe | | | |

* Tested and approved for non-fatty food objects.

1.3 SG-a-S/H

The S and the H variants are identical except the very end of the tool (C) that is Soft in case of the S variant.

| Properties | Minimum | Typical | Maximum | Unit |
|-----------------------------------|---------------------|-------------|----------------------|----------------|
| Max payload SG-a-H/SG-a-S | - | - | 2.2/1.5* 4.85/3.3 | [kg] [lb] |
| Gripping time | 0 | - | 32 | [Grip/min] |
| Work range Grip dimensions (A) | 11 0.43 | - | 75 2.95 | [mm] [inch] |
| Work range Grip depth (B) | - | 38 1.496 | | [mm] [inch] |
| Soft part (SG-a-S) (C) | | 16 0.63 | | [mm] [inch] |
| Dimensions (H x Ømax) | 76 x 112 3 x 4.4 | | | [mm] [inch] |
| Weight (smart-lock included) | 0.168 0.37 | | | [kg] [lb] |

* Test object: 3D-printed ABS cylinder Ø65mm. Payload depends on shape, softness and friction of the product.

Work Range

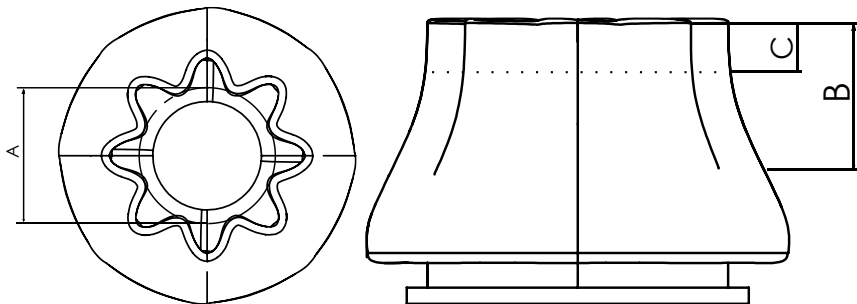

SG tool dimensions

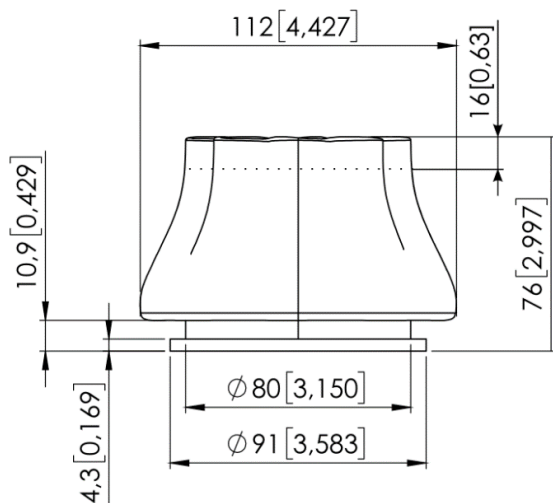

All dimensions are in mm and [inches].

SG-a-H Workpiece examples

The table below shows a list of differently shaped workpieces picked with an SG-a-H tool, they all share the same grip width, roughness and fragility.

| Workpiece | Dimensions [DxH] | Payload |
|------------------------|------------------|---------|
| Cylinder | 65mm x 30mm | 2.2kg |
| Hexagon | 65mm x 30mm | 1.8kg |
| Equilateral triangle | 65mm x 30mm | 0.7kg |
| Round | 65mm | 0.5kg |
| Ellipse | 65mm x 30mm | 1.0kg |
| Square | 65mm x 30mm | N/A |
| Cylinder / Round stick | 30mm x 65mm | 1.6kg |

Test object material: 3D-printed ABS

Center of Gravity

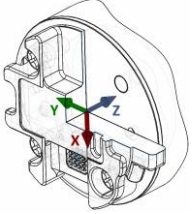
| Coordinate system | TCP [mm] | Center of Gravity [mm] | Weight* |
|--|---------------------|--------------------------|---------------------|
|  | X=0 Y=0 Z=154 | cX=-12 cY=-5 cZ=45 | 0.932 kg 2.05 lb |

*Including the SG base unit.

Percentage to mm conversion graph

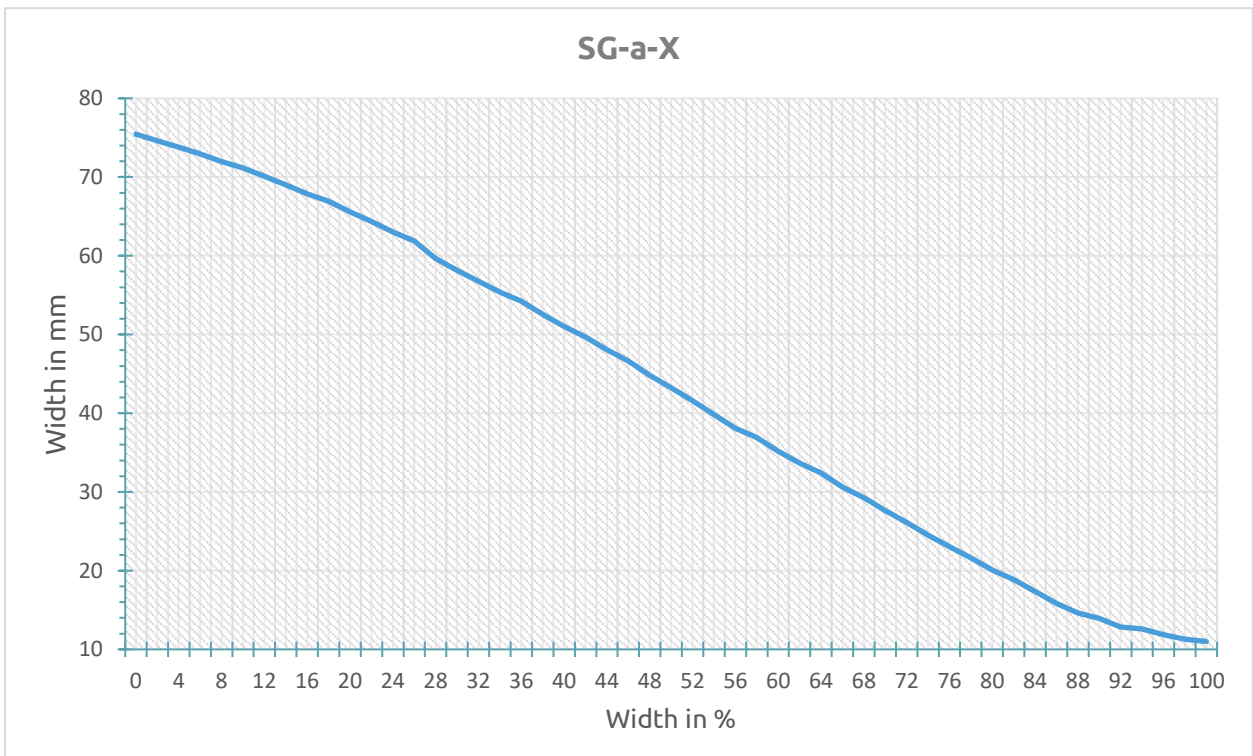

1.4 SG-b-H

| Properties | Minimum | Typical | Maximum | Unit |
|-----------------------------------|-----------------------|------------|-------------|----------------|
| Max payload* | - | - | 1.1 2.42 | [kg] [lb] |
| Gripping time | 0 | - | 32 | [Grip/min] |
| Work range Grip dimensions (A) | 24 0.94 | 79 3.1 | 118 4.65 | [mm] [inch] |
| Work range Grip depth (B) | - | 40 1.57 | | [mm] [inch] |
| Dimensions (H x Ømax) | 77x109 3.03 x 4.29 | | | [mm] [inch] |
| Weight (smart lock included) | 0.172 0.379 | | | [kg] [lb] |

*Test object: 3D-printed ABS cylinder Ø30mm (horizontal workpiece). Payload depends on shape, softness and friction of the product.

Work range

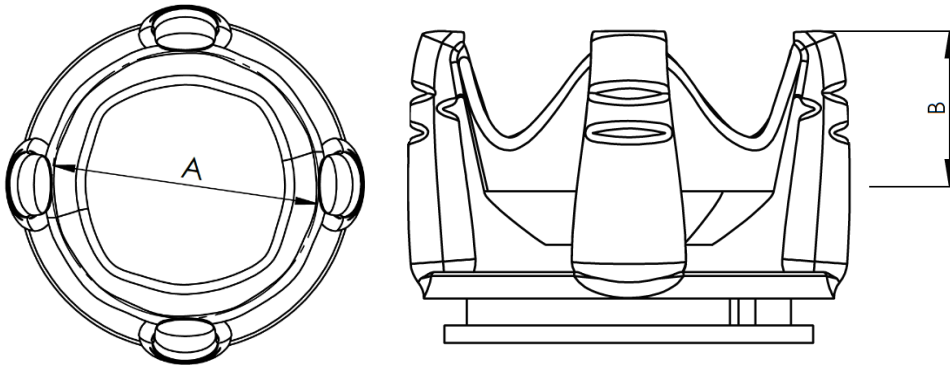

SG tool dimensions

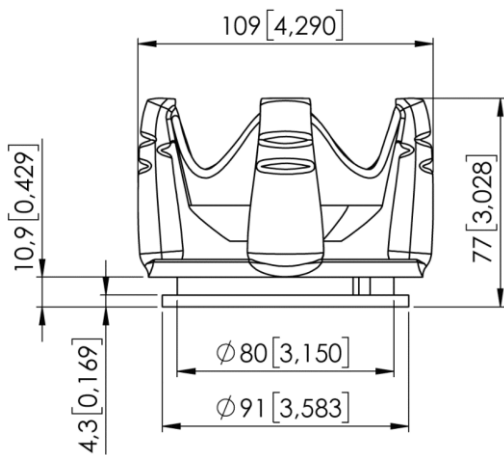

All dimensions are in mm and [inches].

Workpiece examples

The table below shows a list of differently shaped workpieces picked with an SG-b-H, they all share the same grip width, roughness and fragility.

| Workpiece | Dimensions (DxH) | Payload |
|------------------------|------------------|---------|
| Cylinder | 65mm x 30mm | 0.6kg |
| Hexagon | 65mm x 30mm | 0.5kg |
| Equilateral triangle | 65mm x 30mm | N/A |
| Round | 65mm | 1.0kg |
| Ellipse | 65mm x 30mm | 0.3kg |
| Square | 65mm x 30mm | 0.5kg |
| Cylinder / Round stick | 30mm x 65mm | 1.1kg |

Test object material: 3D-printed ABS

Center of Gravity

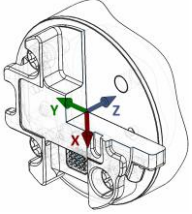
| Coordinate system | TCP [mm] | Center of Gravity [mm] | Weight* |
|--|---------------------|--------------------------|---------------------|
|  | X=0 Y=0 Z=155 | cX=-12 cY=-5 cZ=46 | 0.937 kg 2.06 lb |

*Including the SG base unit.

Percentage to mm conversion graph

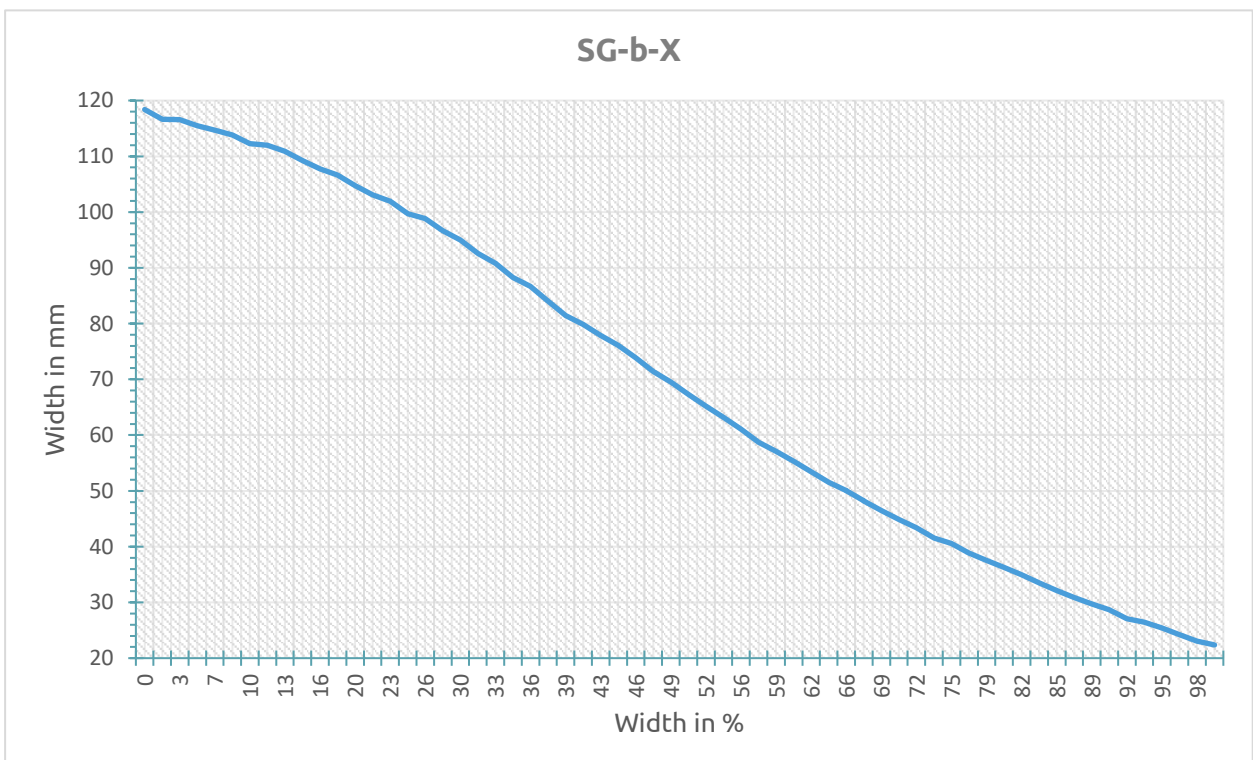

1.4.1 How to handle a workpiece

With the elastic silicone SG tools, the gripper can handle a wide range of workpieces, for a high number of applications. Different tool designs have some overlap in capability when handling the same workpiece, but the tools have different characteristics and do have individual effectiveness on a given workpiece.

Soft silicone

Some SG tool designs has a soft silicone part in the top of the gripper. These tools are better suited for handling fragile workpieces and/or workpieces with a high variance in size, compared to the hard silicone tools. This is due to the more "forgiving" nature of the soft part. The user may experience a reduced payload compared to the hard silicone tools.

To handle a workpiece properly, the user must know some parameters that are defined by the general conditions of the workpiece and its presentation in the application. This helps to define which tool to choose and the actual grip width on it.

A general overview of such parameters is listed below:

- Shape
- Dimension
- Weight
- Roughness
- Fragility
- Orientation of pick/placement

For a better understanding of how to handle workpieces with different parameters, tests were conducted with a SG-a-H tool, see table below.

| Example of material | Workpiece | Dimension | Weight | Roughness | Shape | Actual gripping width |
|----------------------|----------------------|-----------|--------|-----------|----------|-----------------------|
| Smooth wood (Sanded) | Round stick | 27mm | 32g | 5 | Cylinder | 20mm |
| Polished metal | Aluminum cube | 35x25mm | 512g | 1 | Square | 15mm |
| Rough metal | Aluminum cylinder | 60mm | 490g | 8 | Cylinder | 55mm |
| Plastic | PET Bottle | 65mm | 431g | 1 | Cylinder | 50mm |
| | POM-C | 50mm | 221g | 2 | Cylinder | 42mm |
| | POM-C | 50mm | 1410g | 2 | Cylinder | 15mm |
| Glass | Drinking glass | 68mm | 238g | 1 | Cylinder | 50mm |
| Organic material | Tomato | 54mm | 92g | 2 | Round | 53mm |
| | Mushroom | 40mm | 8g | 10 | Round | 39mm |
| | Grape | 20mm | 7g | 10 | Oval | 16mm |
| Carbonfiber | Carbonfiber cylinder | 38mm | 48g | 7 | Cylinder | 29mm |

Notice objects with high weight needs higher force asserted upon them, therefor the small gripping width.



NOTE:

The results shown in the table above, should be considered as indicative and may vary. The actual grip width always require testing, for verification.

It is often a good idea to set a target width smaller, than actual workpiece width, to reach a higher surface contact area and to accommodate for vibrations and other unexpected conditions.

For heavy and large workpieces test at low velocity and with caution.



NOTE:

For individual SG-tool examples. See the separate SG-tool manual.

The criteria for roughness are a basic scale from 1-10, here are the benchmarks used to determine the values.

| Roughness | Description | Example |
|-----------|-----------------|-------------------|
| 1 | Polished/Smooth | Polished Metal |
| 5 | Textured | Cardboard |
| 10 | Rough | Sandblasted Metal |



WARNING:

Sharp edges, on a workpiece, may damage the silicone and reduce lifetime of the tool.